



Manufacturer of shut-off and control valves

TECHNICAL DATA SHEET

**Butterfly valve Elephant
WBV0232E-2W-Fb-H DN25-32 16 bar aluminum,
interflanged, with handle**



+34 900 433 073, sales@valveelephant.com
Carrer d'Aragó, 264, 3-1, 08007 Barcelona, Spain

1. GENERAL PRODUCT INFORMATION

1.1. Product name: Butterfly valve Elephant WBV0232E-2W-Fb-H DN25-32 16 bar aluminum, interflanged, with handle.

1.2. Purpose: Rotary disk gate valve is designed for use as shut-off or regulating valves for flow control in heat supply systems, water supply systems, in technological processes of food, chemical, oil and gas, pulp and paper and other industries.

1.3. Principle of operation: The valves are opened and closed by turning the disk by 90°. Opening is performed by turning the handle or gearbox hand wheel counterclockwise, closing clockwise.



1.4. Deciphering the designation:

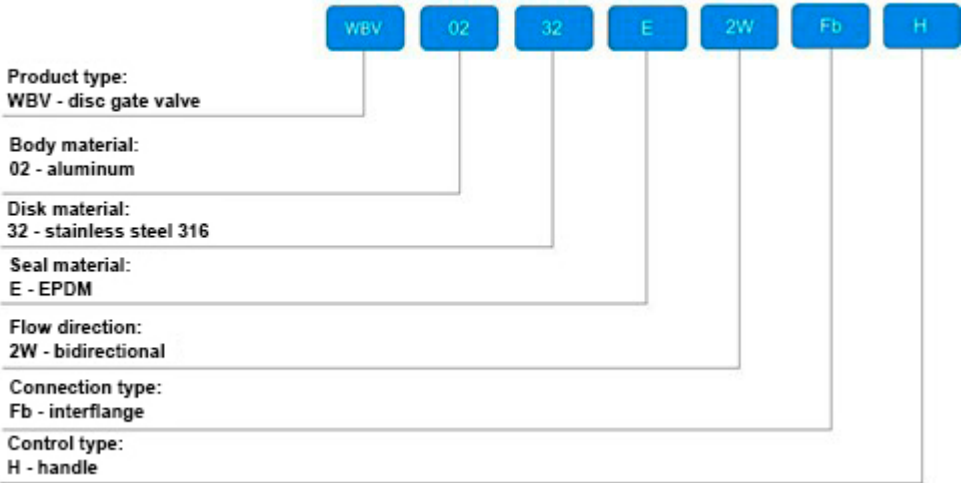

2. MAIN TECHNICAL DATA AND CHARACTERISTICS

Table 1

Nominal diameter DN, mm	25 / 32
Nominal pressure, bar	16
Working medium temperature t, °C	from -20 to +120
Working medium	cold and hot water, air without oil and grease, other media neutral to the material
Flow direction	double-sided
Control type	handle
Connection to pipeline	interflanged
Body material	aluminum alloy
Disk material	stainless steel AISI 316L



3. BASIC PART MATERIALS

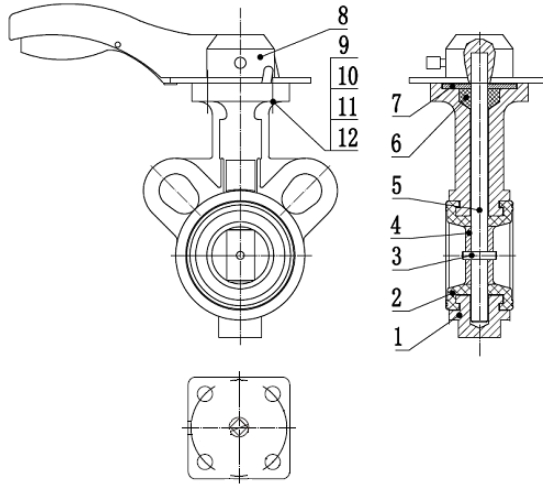

Table 2

Nº	Name	Material	Nº	Name	Material
1	Body	aluminum alloy	7	Plate	steel
2	Seat seal	EPDM	8	Handle	ductile iron
3	Pin	stainless steel AISI 304	9	Bolt	stainless steel SS 201
4	Disk	stainless steel AISI 316L	10	Gasket	stainless steel SS 201
5	Rod	stainless steel SS 410	11	Nut	stainless steel SS 201
6	Sealing ring	EPDM	12	Gasket	stainless steel SS 201



4. WEIGHT AND DIMENSIONAL PARAMETERS

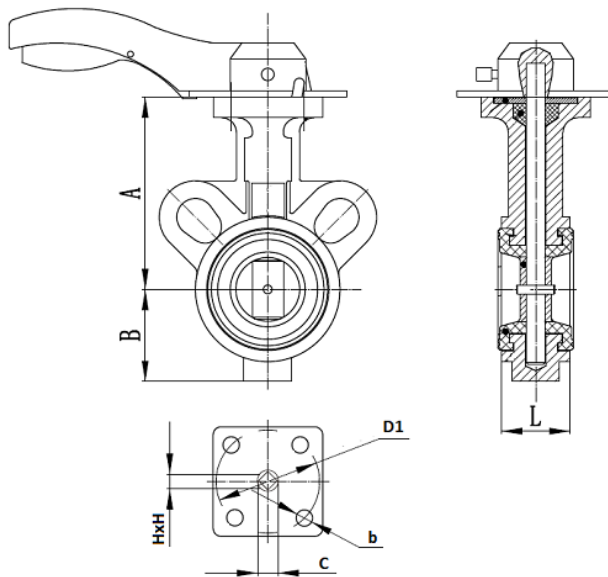

Table 3

DN	A, mm	B, mm	L, mm	C, mm	D1, mm	b, mm	HxH, mm	n-Th	ISO 5211	Torque, Nm	Weight, kg
25	93	44.5	36	10	50	8	9x9	2x14	F05	25	1.05
32	93	44.5	36	10	50	8	9x9	2x19	F05	25	1.05



5. INSTALLATION AND OPERATING INSTRUCTIONS

5.1. Installation, operation and maintenance of the gate valves may be performed by personnel who have studied the gate valve design, safety rules, requirements of the installation, adjustment, operation and maintenance manual and who are certified for the relevant type of work.

5.2. The gate valves should be installed on pipelines for media and parameters specified in the product passport.

5.3. Pipelines should be cleaned (blown out) from dirt, sand, scale before installation.

5.4. The butterfly valves should be installed only between collar flanges.

5.5. The inner diameter of flanges shall correspond to the nominal diameter of the disk butterfly valve.

5.6. The flanges shall be placed flat-parallel to each other at a distance ensuring free (without excessive effort) placement of the gate between them. The sealing surfaces of the flanges shall be free of nicks, pits, burrs and other surface defects.

5.7. Before starting installation, the disk of the butterfly valve should be slightly opened, but in such a way that the disk does not protrude beyond the body of the butterfly valve.

5.7.1. Center the butterfly valve and lightly tighten the bolts (studs), but do not tighten them. Open the rotary bolt disk to the “fully open” position.

5.7.2. Tighten the bolts (studs) so that the flanges and the gate body (metal part) are in contact. The flange connections should be tightened evenly in three or even four passes, in a “crosswise” sequence.

5.7.3. Tightening of bolts on inter-flange connections should be uniform all around. Next, slowly close and open the butterfly valve. If the gate has been installed correctly, the gate should open and close freely.

5.8. Tightness tests shall be carried out in accordance with the company's internal instructions.

5.9. Types, scope and frequency of maintenance.

5.9.1. During operation it is necessary to perform periodic inspections (routine maintenance) within the terms established by the schedule, depending on the mode of operation of the system (unit), but at least once a month.

5.9.2. During inspections it is necessary to check:

- a) general condition of the gate;
- b) condition of fastening connections;
- c) tightness of joints in relation to the external environment;
- d) operability and ability of the gate to fulfill its functions.

5.9.3. In order to ensure long service life of the gate, it is necessary to periodically open and close the gate fully or partially during long “downtime”, more than three months.

5.9.4. Inspections and tests shall be carried out by the personnel operating the system or unit and having the necessary competence and qualifications.



6. CONDITIONS OF TRANSPORTATION AND STORAGE

6.1. Transportation and storage conditions comply with the internal instructions of the company.

6.2. The gates can be transported by any type of transport. At the same time, the gate must be installed on transportation means to exclude the possibility of mechanical damage, internal surfaces must be protected from contamination.

6.3. During transportation and storage the gate must be in the position of incomplete closing, i.e. the locking disk must be in loose contact with the collar surface - without deformation of the rubber.

6.4. When loading and unloading, the gates should be slung by the body.

6.5. The gates should be stored in dry warehouses, protected from direct sunlight and at least 1 m away from heat-emitting devices, as well as not exposed to oil and gasoline.

6.6. During long-term storage of the gate valve it is necessary to inspect it periodically (at least twice a year), remove external dirt and rust, if necessary treat the seat seal with silicone spray lubricant.

7. UTILIZATION

7.1. The product is utilized in accordance with the procedure established at the enterprise (remelting, burial, resale).

7.2. Before sending for utilization, residues of the working medium shall be removed from the fitting. Methods of removal of the working medium and decontamination of the valve shall be approved in accordance with the established procedure at the enterprise operating the product.



8. WARRANTY OBLIGATIONS

8.1. Warranty period - 12 months from the date of commissioning, but not more than 18 months from the date of sale.

8.2. The warranty applies to equipment installed and used in accordance with the installation instructions and product specifications described in this data sheet.

8.3. The manufacturer guarantees compliance of the product with safety requirements, provided that the consumer complies with the rules of transport, storage, installation and operation.

8.4. The warranty covers all defects caused by the fault of the manufacturer.

8.5. The warranty does not apply:

- parts and materials of the product subject to wear and tear;
- for cases of damage caused by:
 - modifications to the original design of the product;
 - violation of general installation recommendations;
 - faults caused by improper maintenance and storage; improper operation and use of the equipment.

9. WARRANTY TERMS

9.1. Claims to the quality of the goods may be made during the warranty period.

9.2. Defective products are repaired or exchanged for new ones free of charge during the warranty period. ELEPHANT decides whether to replace or repair the product. The replaced product or its parts resulting from the repair shall become the property of 'ELEPHANT'.

9.3. Costs related to dismantling, installation and transport of the defective product during the warranty period shall not be reimbursed to the Buyer.

9.4. If the claim is unfounded, the Buyer shall pay the costs of diagnostics and expertise of the product.

9.5. Products are accepted for warranty repair (as well as for return) fully assembled.



WARRANTY CARD № _____

№	Product Name	Packs

Name and address of the trading organisation

Date of sale _____ Seller's signature _____

Stamp or seal of the trading organisation _____ Acceptance stamp _____

I agree with the terms and conditions of the warranty:

Buyer _____ (signature)

Warranty period - 12 months from the date of commissioning, but not more than 18 months from the date of sale.

For warranty repairs, complaints and product quality claims, please contact ELEPHANT at:
Carrer d'Aragó,264,3-1,08007 Barcelona, Spain_E-mail address: sales@valveelephant.com.

When making a complaint about the quality of goods, the buyer shall present the following documents:

1. A free-form application, which shall specify:

- name of the organisation or full name of the buyer, actual address, contact telephone numbers;
- name and address of the organisation that carried out the installation;
- basic parameters of the system in which the product was used;
- a brief description of the defect.

2. Document confirming the purchase of the product (delivery note, receipt).

3. Act of hydraulic test of the system in which the product was installed.

4. This completed warranty card.

A note on the return or exchange of goods _____

Date: «__» _____ 202__ yr. Caption _____

