



Manufacturer of shut-off and control valves

TECHNICAL DATA SHEET

**Ball valve ELEPHANT BVxxP(3pc)-FP-F-ISO-H DN15-100
40/25/16 bar three-piece, stainless steel, full bore, flanged,
with ISO-flange and handle**



+34 900 433 073, sales@valveelephant.com
Carrer d'Aragó, 264, 3-1, 08007 Barcelona, Spain

1. GENERAL PRODUCT INFORMATION

1.1. Product Name: Ball Valve ELEPHANT BVxxP(3pc)-FP-F-ISO-H DN15-100 40/25/16 bar three-piece ball valve, stainless steel, full bore, flanged, with ISO-flange and handle.

1.2. Purpose: Ball valves are used as shut-off valves in heating, water supply systems, in steam, fuel and pneumatic systems with compressed air and neutral gases. Installation of valves of this series is possible in systems transporting liquid and gaseous media (water, oil, oils, steam, air, alcohols, glycol, etc.), not aggressive to the materials of the valve.

1.3 Principle of operation: The working flow is closed by means of a locking element, which is a ball with a through cylindrical hole. The ball is rotated around the axis by means of a handle mounted on the body. It is sufficient to turn it by 90 degrees to completely shut off the flow.



1.4. Deciphering of the designation:

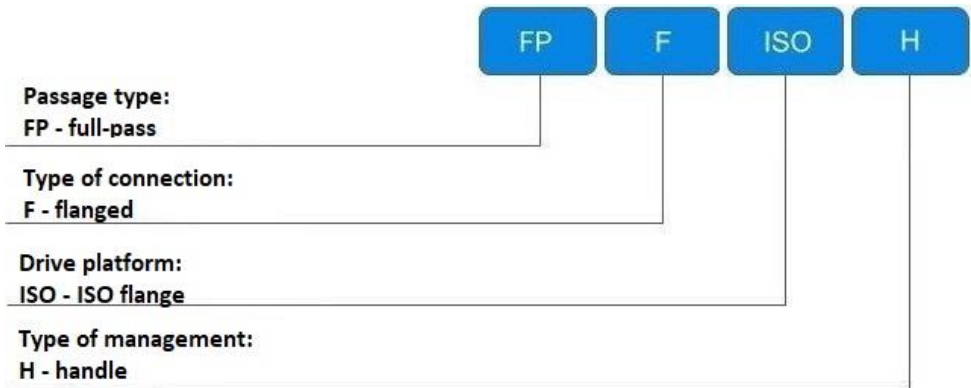
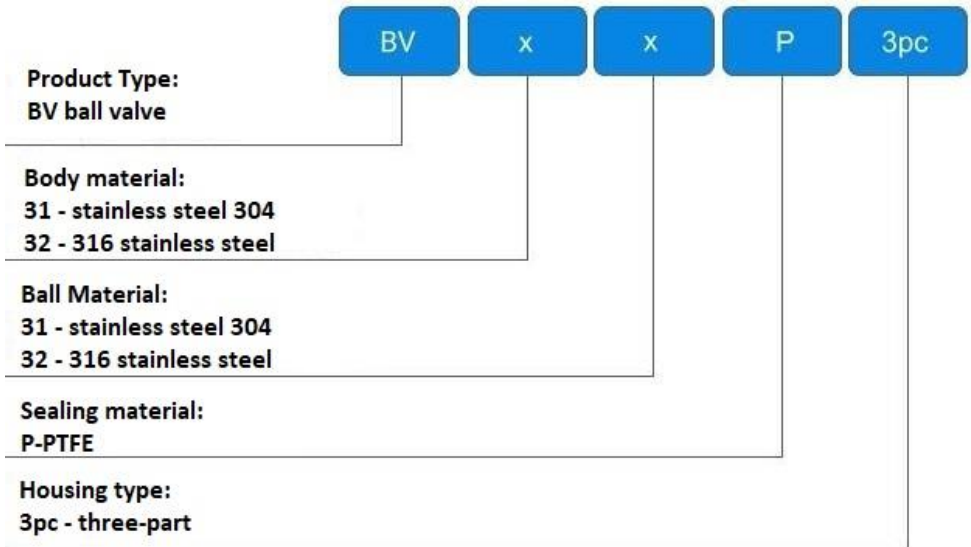

2. BASIC TECHNICAL DATA AND CHARACTERISTICS

Table 1. Characteristics

Nominal diameter DN, mm	15-100
Nominal pressure PN, bar	DN15-50 – 40 DN65-80 – 25 DN100 – 16
Working medium temperature t, °C	-20 to +180
Working medium	water, steam, petroleum products and other liquid or gaseous media neutral to valve materials
Connection to pipeline	flanged
Type of through section	full bore
Sealing class of the ball valve	«A»
Body material	stainless steel CF8 /AISI 304 or stainless steel CF8M /AISI 316
Ball material	stainless steel CF8 /AISI 304 or stainless steel CF8M /AISI 316
Type of control	manual (handle)
Supplement	electric or pneumatic actuators are available pneumatic actuator (ISO 5211-2001)
Service life, years	10
Average life, opening/closing cycles	60 000



3. BASIC MATERIALS

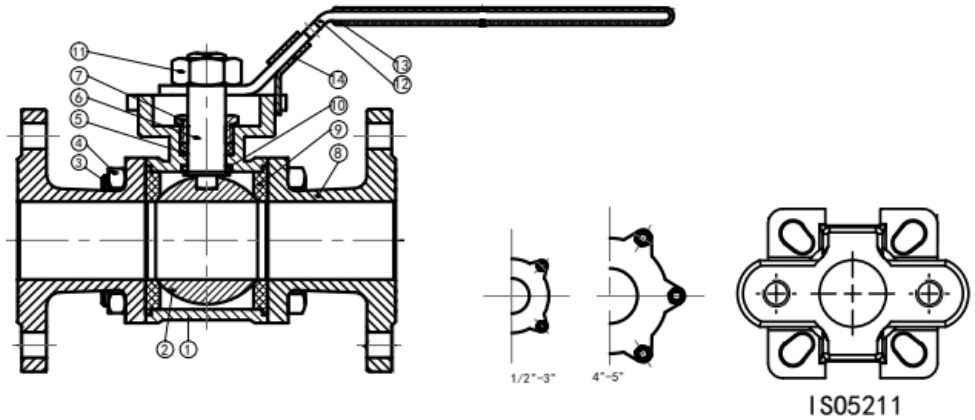

Figure 1 - Detailing

Table 2. Parts Specification

Nº	Part name	Material	Quantity
1	Housing	stainless steel CF8 /AISI 304 or stainless steel CF8M /AISI 316	1
2	Bolt ball	stainless steel CF8 /AISI 304 or stainless steel CF8M /AISI 316	1
3	Bolt	stainless steel SS 201 or stainless steel AISI 304	4~6
4	nut	stainless steel SS 201 or stainless steel AISI 304	6~12



Table continuation 2

№	Part name	Material	Quantity
5	Seal	PTFE	1
6	Stem	stainless steel AISI 304 or stainless steel AISI 316	1
7	Gland	stainless steel SS 201 or stainless steel AISI 304	1
8	Cover	CF8 stainless steel or CF8M stainless steel	2
9	Seat rings	PTFE	2
10	Thrust washer	PTFE	1
11	Nut	stainless steel SS 201 or stainless steel AISI 304	1
12	Handle	stainless steel SS 201 or stainless steel AISI 304	1
13	Handle shell	PVC	1
14	Stopper	stainless steel SS 201 or stainless steel AISI 304	1



4. WEIGHT, DIMENSIONS AND TECHNICAL PARAMETERS

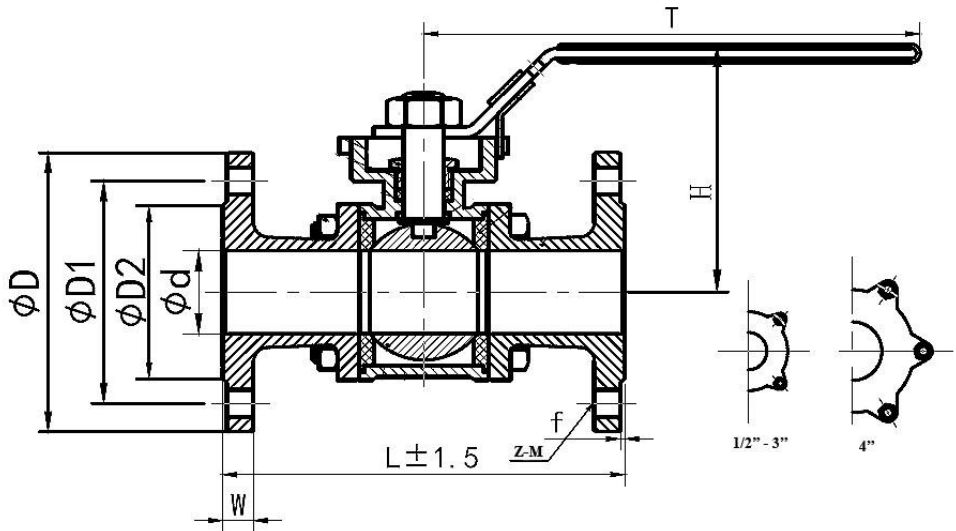

Figure 2 - Dimensions

Table 3. Dimensional characteristics

DN	d	D	D1	D2	W	f	L±1.5	T	H	Z-øM
	mm									pcs-mm
15	15	95	65	46	17	2	130	131	71	4-ø14
20	20	105	75	58	18	2	150	131	74	4-ø14
25	25	115	85	68	18	2	160	167	97	4-ø14
32	32	140	100	78	19	2	180	167	110	4-ø18
40	40	150	110	88	19	2	200	193	117	4-ø18
50	50	165	125	102	19	3	230	193	125,5	4-ø18
65	65	185	145	122	22	3	290	242	135,5	8-ø18
80	80	200	160	140	24	3	310	272	157	8-ø18
100	100	234	190	161	24	3	350	295	181	8-ø22



Table 4. Connection dimensions, torque and weight

DN	Stem square valve, mm	Crane stem torque, Nm	ISO 5211	Вес, кг
15	9x9	8	F03/F04	2,06
20	9x9	10	F03/F04	2,87
25	11x11	14	F04/F05	3,625
32	11x11	20	F04/F05	5,27
40	14x14	29	F05/F07	6,465
50	14x14	42	F05/F07	8,285
65	17x17	85	F07/F10	13
80	17x17	146	F07/F10	17,255
100	17x17	235	F07/F10	25,705

Table 5. Bolt tightening torques using a torque wrench.

DN	Permissible tightening torque range, Nm	Optimum tightening torque value, Nm
10	14,7 ÷ 34	25
15	14,7 ÷ 74	25
20	14,7 ÷ 34	25
25	14,7 ÷ 34	25
32	34 ÷ 74	54
40	34 ÷ 74	54
50	34 ÷ 74	54
65	54 ÷ 123	89
80	84 ÷ 196	137
100	147 ÷ 309	230



5. OPERATING INSTRUCTIONS

5.1. It is forbidden:

- use ball valves as regulating valves;
- allow the working medium to freeze inside the ball valve;
- operate the product under conditions and parameters that do not correspond to the nameplate values;
- to perform installation, dismantling, preventive maintenance work in the presence of working medium and pressure in the pipeline;
- use ball valves instead of plugs when testing pipeline systems;
- use ball valves as supports for pipelines;
- use levers (gas keys, extensions) that increase the leverage of the handle to operate the valve;
- install products on systems with a working medium containing abrasive components.

5.2. To avoid water hammer in the pipeline to open and close the valve smoothly, without jerking.

5.3 It is not allowed to operate the valve with loosened handle fastening nut, as it may lead to stem neck breakage.

5.3 For preventive purposes, as well as to prevent the formation of karst deposits on the surface of the ball, it is required several times a year to perform 2-3 cycles open-close.

5.4 If the ball valve is used with a working medium with a high content of mechanical impurities, the installation of additional filtering equipment at the inlet is mandatory.

5.5. During installation and operation of cranes, safety requirements must be met in accordance with the procedure established at the enterprise.

5.6. Maintenance of the valves in operation is reduced to periodic inspections. In this case, the stroke of the valve stem is checked until the valve is fully opened-closed, no leaks are detected.



6. INSTALLATION INSTRUCTIONS

6.1. The ball valve may be installed on the pipeline section in any mounting position that provides ease of operation and access to the actuator.

6.2 Installation and dismantling of the product, as well as any repair or adjustment operations should be performed in the absence of pressure in the system.

6.3 Before installing the valve, the pipeline should be cleaned of dirt, sand, scale and any foreign objects.

6.4 The ball valve should not experience loads from the pipeline (bending, compression, tension, torsion, warping, vibration, misalignment of spigots). If necessary, supports or compensators should be provided to reduce the load on the valve from the pipeline.

6.5 After the installation should be checked the performance of the valve by turning the handle, while moving parts should move smoothly, without jerks and seizures. Tightness tests of connections are carried out in accordance with the procedure established at the enterprise.

7. УСЛОВИЯ ТРАНСПОРТИРОВКИ И ХРАНЕНИЯ

7.1. Ball valves are transported in accordance with the procedure established at the enterprise.

7.2. Storage should be carried out in the factory packaging in accordance with the procedure established at the enterprise.

7.3. At shipment to the customer the valves are not subjected to preservation, as the materials used in their manufacture are weatherproof and have a protective coating.

7.4 During storage, transportation ball valves do not harm the environment and human health.

8. UTILIZATION

8.1. The product is disposed of in accordance with the procedure established at the enterprise (remelting, burial, resale).



9. WARRANTY OBLIGATIONS

9.1. Warranty period - 12 months from the date of commissioning, but not more than 18 months from the date of sale.

9.2. The warranty applies to equipment installed and used in accordance with the installation instructions and product specifications described in this data sheet.

9.3. The manufacturer guarantees compliance of the product with safety requirements, provided that the consumer complies with the rules of transport, storage, installation and operation.

9.4. The warranty covers all defects caused by the fault of the manufacturer.

9.5. The warranty does not apply:

- parts and materials of the product subject to wear and tear;
- for cases of damage caused by:
 - modifications to the original design of the product;
 - violation of general installation recommendations;
 - faults caused by improper maintenance and storage; improper operation and use of the equipment.

10. WARRANTY TERMS

10.1. Claims to the quality of the goods may be made during the warranty period.

10.2. Defective products are repaired or exchanged for new ones free of charge during the warranty period. ELEPHANT decides whether to replace or repair the product. The replaced product or its parts resulting from the repair shall become the property of 'ELEPHANT'.

10.3. Costs related to dismantling, installation and transport of the defective product during the warranty period shall not be reimbursed to the Buyer.

10.4. If the claim is unfounded, the Buyer shall pay the costs of diagnostics and expertise of the product.

10.5. Products are accepted for warranty repair (as well as for return) fully assembled.



WARRANTY CARD № _____

№	Product Name	Packs

Name and address of the trading organisation _____

Date of sale _____ Seller's signature _____

Stamp or seal of the trading organisation _____ Acceptance stamp _____

I agree with the terms and conditions of the warranty:

Buyer _____ (signature)

Warranty period - 12 months from the date of commissioning, but not more than 18 months from the date of sale.

For warranty repairs, complaints and product quality claims, please contact ELEPHANT at: Carrer d'Aragó,264,3-1,08007 Barcelona, Spain E-mail address: sales@valveelephant.com.

When making a complaint about the quality of goods, the buyer shall present the following documents:

1. A free-form application, which shall specify:
 - name of the organisation or full name of the buyer, actual address, contact telephone numbers;
 - name and address of the organisation that carried out the installation;
 - basic parameters of the system in which the product was used;
 - a brief description of the defect.
2. Document confirming the purchase of the product (delivery note, receipt)..
3. Act of hydraulic test of the system in which the product was installed.
4. This completed warranty card.

A note on the return or exchange of goods _____

Date: « ___ » _____ 202__r. Caption _____

