



Manufacturer of shut-off and control valves

TECHNICAL DATA SHEET

**Ball valve ELEPHANT BV32xP(3pc)-FP-W-ISO-H
DN10-100 63/40/25 bar stainless steel, full bore, welded, with
ISO-flange and handle**



+34 900 433 073, sales@valveelephant.com
Carrer d'Aragó, 264, 3-1, 08007 Barcelona, Spain

1. GENERAL PRODUCT INFORMATION

1.1. Product Name: Ball valve ELEPHANT BV32xP(3pc)-FP-W-ISO-H DN10-100 63/40/25 bar stainless steel, full bore, welded, with ISO-flange and handle.

1.2. Purpose: Ball valves are used as shut-off valves in heating, water supply systems, in steam, fuel and pneumatic systems with compressed air and neutral gases. Installation of valves of this series is possible in systems transporting liquid and gaseous media (water, oil, oils, steam, air, alcohols, glycol, etc.), not aggressive to the materials of the valve.

1.3 Principle of operation: The working flow is closed by means of a locking element, which is a ball with a through cylindrical hole. The ball is rotated around the axis by means of a handle mounted on the body. It is sufficient to turn it by 90 degrees to completely shut off the flow.



1.4. Deciphering of the designation:

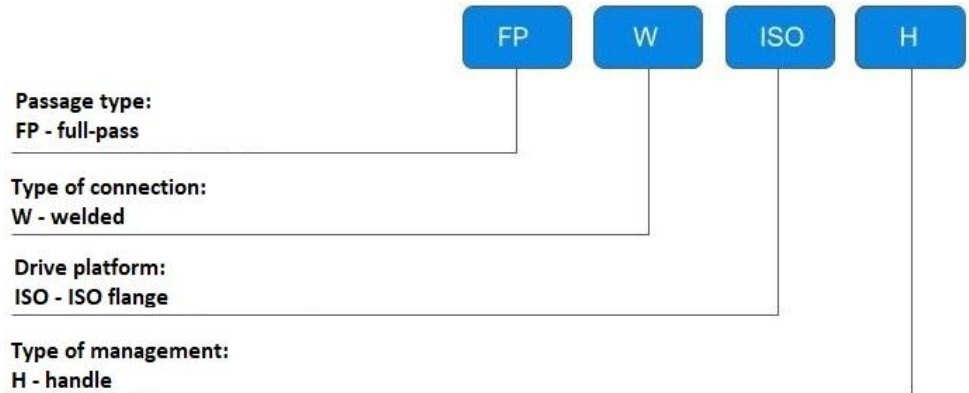
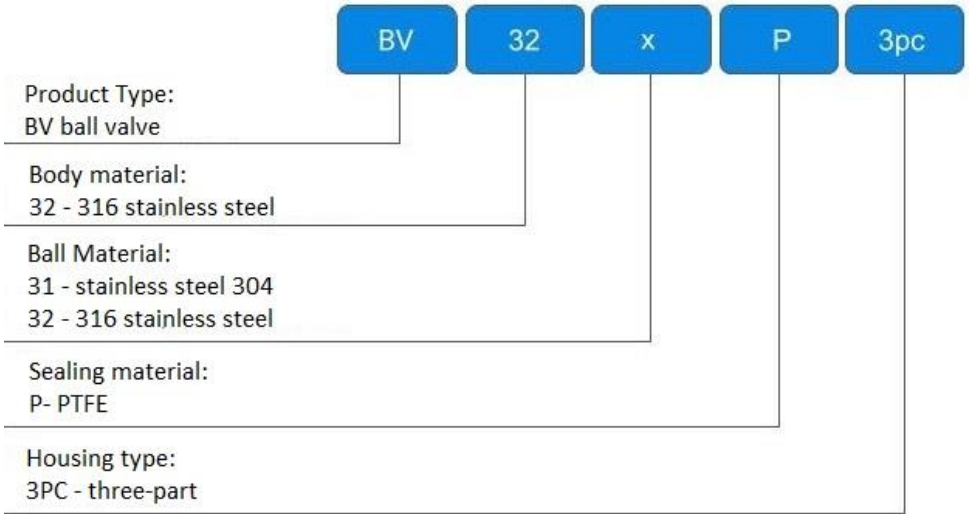

2. BASIC TECHNICAL DATA AND CHARACTERISTICS

Table 1

Nominal diameter DN, mm	10÷100
Nominal pressure PN, bar	DN10÷32 – 63 DN40÷50 – 40 DN65÷100 – 25
Operating medium temperature t, °C	-20 to +200
Operating medium	water, steam, petroleum products and other liquid or gaseous media neutral to valve materials
Pipeline connection	welding/welding
Type of passage section	full bore
Ball valve tightness class	«A»
Control type	manual
Supplement	electric or pneumatic actuator (ISO 5211-2001) pneumatic actuator (ISO 5211-2001)
Average service life, years	10
Average life, closing/opening cycles	40 000 – 60 000



3. TEMPERATURE-PRESSURE DIAGRAM

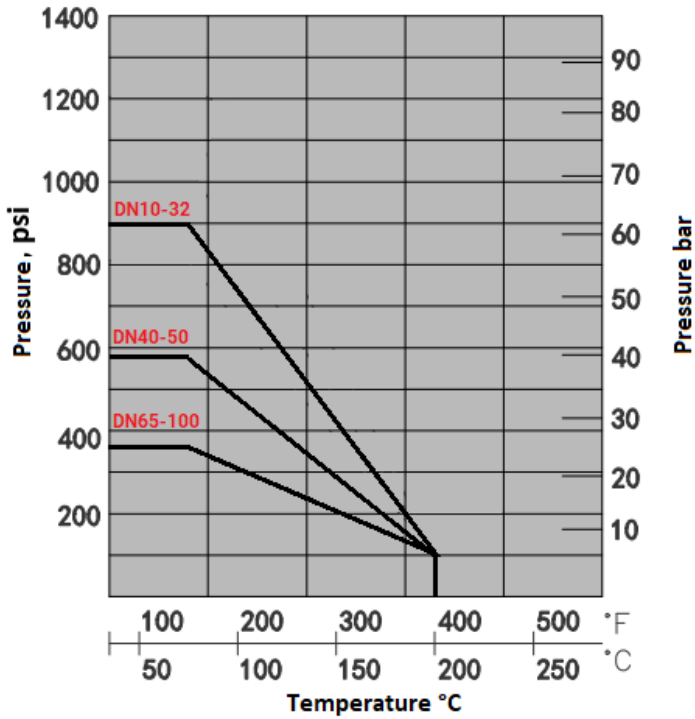

4. BASIC MATERIALS

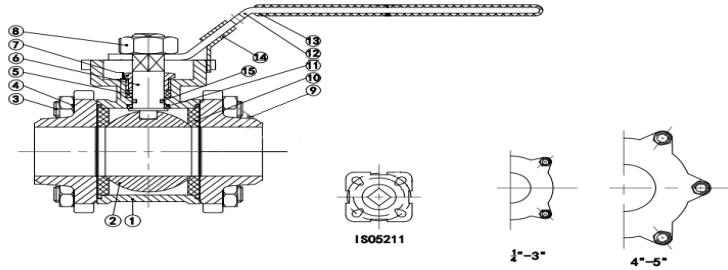

Table 2

Nº	Part name	Material	Quantity
1	Body	SS316	1
2	Shutter ball	S304 / S316	1
3	Bolt	S201 / S304	4~6
4	Nut	S201 / S304	4~6
5	Seal	PTFE	1
6	Stem	SS304 / SS316	1
7	Gland	S201 / S304	1
8	Nut	S201 / S304	1
9	Cover	WCB/CF8/CF8M	2
10	Seat rings	PPL	2
11	Thrust washer	PTFE	1
12	Handle	S201 / S304	1
13	Handle shell	PVC	1
14	Stopper	S201 / S304	1
15	O-ring	VITON	1



5. WEIGHT AND DIMENSIONAL PARAMETERS

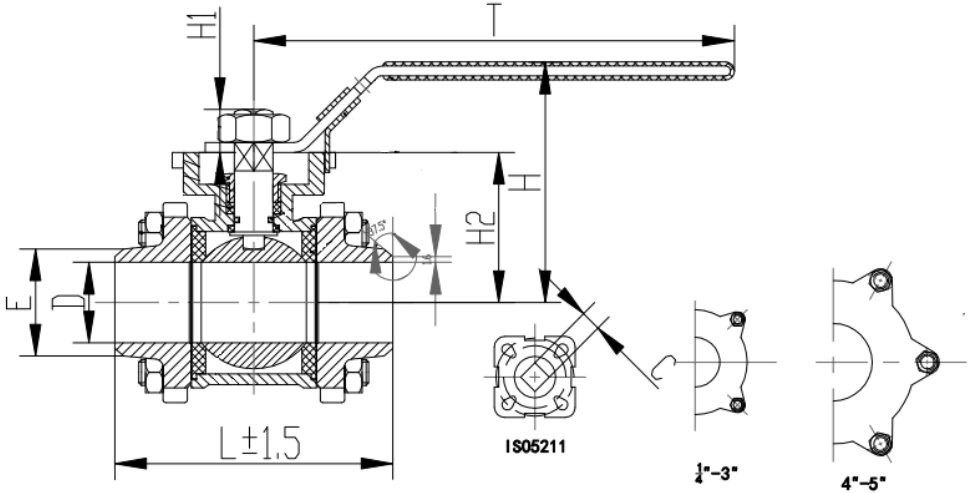

Table 3

DN	D	L±1.5	H	H1	H2	E	T	C	Torque	ISO	Weight
									on the shaft	5211	
									Nm	-	kg
									mm		
10	10	63	70	9	38,9	17,2	131	9	8	F03/F04	0,578
15	15	65	80	9	40	21,3	131	9	11	F03/F04	0,645
20	20	75	74	9	43,9	26,7	131	9	14	F03/F04	0,810
25	25	83	86	13,5	53	33,5	167	11	18	F04/F05	1,085
32	32	98	95	13,5	56	42,2	167	11	28	F04/F05	1,66
40	40	112	116	15	60	48,3	193	14	45	F05/F07	2,195
50	50	135	123	15	75	60,5	193	14	52	F05/F07	3,025
65	65	175	145	21	97	73,2	242	17	67	F07/F10	5,910
80	80	198	154	21	112	88,9	272	17	95	F07/F10	8,135
100	100	246	165	21	122	114,3	295	17	125	F07/F10	15,15



Table 4. Torques for tightening bolts with a torque wrench.

	Nominal diameter bolt threads	Permissible tightening torque range, Nm	Optimum tightening torque value, Nm
DN10	M8	14,7 ÷ 34	25
DN15	M8	14,7 ÷ 74	25
DN20	M8	14,7 ÷ 34	25
DN25	M8	14,7 ÷ 34	25
DN32	M10	34 ÷ 74	54
DN40	M10	34 ÷ 74	54
DN50	M10	34 ÷ 74	54
DN65	M12	54 ÷ 123	89
DN80	M14	84 ÷ 196	137
DN100	M16	147 ÷ 309	230

6. OPERATING INSTRUCTIONS

6.1. It is forbidden:

- Use ball valves as control valves;
- Allow the process medium to freeze inside the ball valve;
- Operate the product under conditions and at parameters that do not correspond to the nameplate values;
- Perform installation, dismantling, preventive maintenance work in the presence of working medium and pressure in the pipeline;
- Use ball valves instead of plugs when testing pipeline systems;
- Use valves as supports for pipelines;
- Use levers (gas wrenches, extensions) that increase the leverage of the handle to operate the valve;
- Install the products on systems with media containing abrasive components.

6.2. To avoid water hammer in the pipeline to open and close the valve smoothly, without jerking.

6.3 It is not allowed to operate the valve with loosened handle fastening nut, as it may lead to stem neck breakage.

6.3 For preventive purposes, as well as to prevent the formation of karst deposits on the surface of the ball, it is required several times a year to perform 2-3 cycles “open-close” .

6.4 If the ball valve is used with a working medium with a high content of mechanical impurities, the installation of additional filtering equipment at the inlet is mandatory.

6.5. During installation and operation of cranes must be carried out in accordance with the procedure established at the enterprise.

6.6. Maintenance of the valves in operation is reduced to periodic inspections. In this case, the stroke of the valve stem is checked until the valve is fully opened-closed, no leaks are detected.



7. INSTALLATION INSTRUCTION

7.1. The ball valve may be installed on the pipeline section in any mounting position that allows easy operation and access to the actuator.

7.2. Installation and dismantling of the product, as well as any repair or adjustment operations must be carried out when the system is depressurized.

7.3 Before installing the valve, the pipeline must be cleaned of dirt, sand, scale and any foreign objects.

7.2 When installing the valve on a horizontal pipeline should be fully open.

7.4. When installing the valve on a vertical pipeline:

- When welding the top end, the valve must be fully open (to prevent sparks from damaging the ball surface and the seal);
- When welding the lower end, the valve must be completely closed (to avoid draught from the heat of welding).

7.5. Avoid overheating the ball valve during welding operations (if the surface temperature of the body at the valve seat exceeds 100 degrees Celsius). If necessary, a damp cloth can be used to cool down the valve body.

7.6. ATTENTION! It is forbidden to open or close the welded valve until it cools down completely.

7.7 The ball valve must not be subjected to loads from the pipeline (bending, compression, tension, torsion, distortion, vibration, misalignment of spigots). If necessary, supports or compensators should be provided to reduce the load on the valve from the pipeline.

7.8. After installation, check that the crane is operational by turning the handle, while moving parts should move smoothly, without jerks and jams. Tightness tests of connections are carried out in accordance with the procedure established at the enterprise.



8. TRANSPORTATION AND STORAGE CONDITIONS

8.1. Ball valves are transported in accordance with the procedure established at the enterprise.

8.2. Storage should be carried out in the factory packaging in accordance with the procedure established at the enterprise.

8.3. At shipment to the customer the valves are not subjected to preservation, as they have a protective coating, and the materials used in their manufacture are weatherproof.

8.4 During storage, transportation ball valves do not harm the environment and human health.

9. UTILIZATION

9.1. The product is disposed of in accordance with the procedure established at the enterprise (remelting, burial, resale).



10. WARRANTY OBLIGATIONS

10.1. Warranty period - 12 months from the date of commissioning, but not more than 18 months from the date of sale.

10.2. The warranty applies to equipment installed and used in accordance with the installation instructions and product specifications described in this data sheet.

10.3. The manufacturer guarantees compliance of the product with safety requirements, provided that the consumer complies with the rules of transport, storage, installation and operation.

10.4. The warranty covers all defects caused by the fault of the manufacturer.

10.5. The warranty does not apply:

- parts and materials of the product subject to wear and tear;
- for cases of damage caused by:
 - modifications to the original design of the product;
 - violation of general installation recommendations;
 - faults caused by improper maintenance and storage; improper operation and use of the equipment.

11. WARRANTY TERMS

11.1. Claims to the quality of the goods may be made during the warranty period.

11.2. Defective products are repaired or exchanged for new ones free of charge during the warranty period. ELEPHANT decides whether to replace or repair the product. The replaced product or its parts resulting from the repair shall become the property of 'ELEPHANT'.

11.3. Costs related to dismantling, installation and transport of the defective product during the warranty period shall not be reimbursed to the Buyer.

11.4. If the claim is unfounded, the Buyer shall pay the costs of diagnostics and expertise of the product.

11.5. Products are accepted for warranty repair (as well as for return) fully assembled.



WARRANTY CARD № _____

№	Product Name	Packs

Name and address of the trading organisation _____

Date of sale _____ Seller's signature _____

Stamp or seal of the trading organisation _____ Acceptance stamp _____

I agree with the terms and conditions of the warranty:

Buyer _____ (signature)

Warranty period - 12 months from the date of commissioning, but not more than 18 months from the date of sale.

For warranty repairs, complaints and product quality claims, please contact ELEPHANT at: Carrer d'Aragó,264,3-1,08007 Barcelona, Spain E-mail address: sales@valveelephant.com.

When making a complaint about the quality of goods, the buyer shall present the following documents:

1. A free-form application, which shall specify:

- name of the organisation or full name of the buyer, actual address, contact telephone numbers;
- name and address of the organisation that carried out the installation;
- basic parameters of the system in which the product was used;
- a brief description of the defect.

2. Document confirming the purchase of the product (delivery note, receipt)..

3. Act of hydraulic test of the system in which the product was installed.

4. This completed warranty card.

A note on the return or exchange of goods _____

Date: « ___ » _____ 202__ г. Caption _____

